

VEGAPULS Air 41

Autarkic radar sensor with measured value transmission via radio technology

Continuous level measurement for bulk solids and liquids



Application area

VEGAPULS Air 41 is the ideal sensor for all stand-alone applications with bulk solids and liquids. It is particularly suitable for level measurement in mobile bulk solids silos holding dry mortar, concrete or plaster, as well as in liquid tanks of all kinds.

VEGAPULS Air 41 represents an attractive, low-cost solution as it is easy to install and put into operation and requires no additional power supply.

Your benefit

- Easy installation thanks to autarkic power supply and radio technology
- Exact measuring results independent of product, process and ambient conditions
- Maintenance-free operation due to non-contact 80 GHz radar technology

Function

The sensor emits a radar signal through the antenna. The emitted signal is reflected by the medium and received as an echo by the antenna.

The resulting level is converted into a respective output signal and wirelessly transmitted.

Measured value transmission

Depending on the availability of the radio networks, the device transmits its measured values wirelessly to an LTE-M (LTE-CAT-M1) or NB-IoT (LTE-CAT-NB1) mobile radio or a plant-side LoRaWAN network.

The transmission or evaluation is carried out via an Asset Management System, e.g. VEGA Inventory System.

Technical data

Measuring range	up to 15 m (49.21 ft)
Deviation	≤ 2 mm
Process fitting	Thread G1½, 1½ NPT, R1½
Process pressure	-1 ... 2 bar (-100 ... 200 kPa/-14.5 ... 29.00 psig)
Process temperature	-20 ... +60 °C (-4 ... +140 °F)
Ambient, storage and transport temperature	-20 ... +60 °C (-4 ... +140 °F)
Radio technology	NB-IoT (LTE-Cat-NB1), LTE-M (LTE-CAT-M1), LoRa WAN
Protection rating	IP66/IP67 acc. to IEC 60529, Type 4P acc. to NEMA

Materials

The wetted parts of the instrument are made of PVDF.

Housing version

The sensor housing with high protection class IP66/IP67 enables continuous, maintenance-free operation outdoors.

Application examples

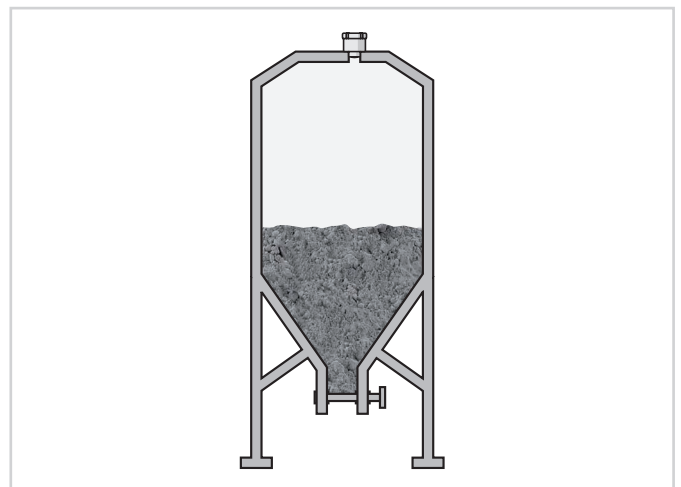

Level measurement in the building material silo



Level measurement in the liquid tank

Adjustment

The device has an integrated Bluetooth module and can be operated wirelessly using standard operating tools:

- Smartphone/tablet (iOS or Android operating system)
- PC/notebook with Bluetooth USB adapter (Windows operating system)

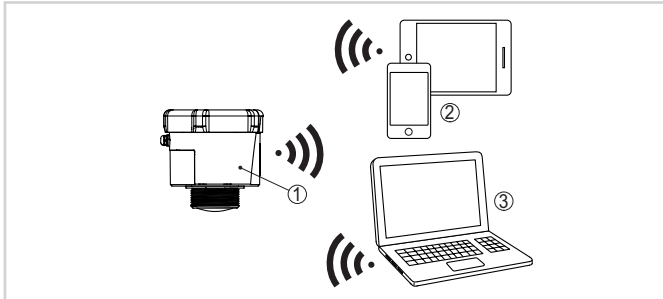

Wireless connection to standard operating devices via Bluetooth

Operation is via a free app from the "Apple App Store", the "Google Play Store" or the "Baidu Store". Alternatively, adjustment can also be carried out via PACTware/DTM and a Windows PC.

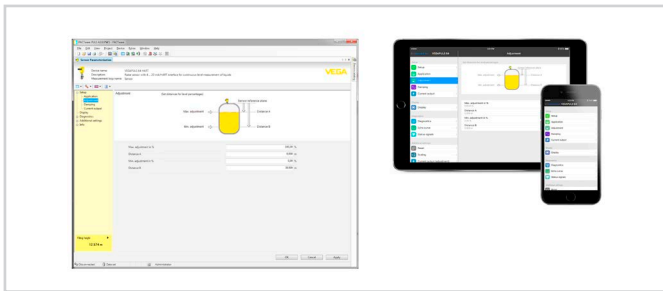

Adjustment via PACTware or app

Voltage supply

The device is supplied with energy by integrated, exchangeable primary cells. The lithium cell used for this purpose is a compact storage device with high cell voltage and capacity for a long service life.

Dimensions

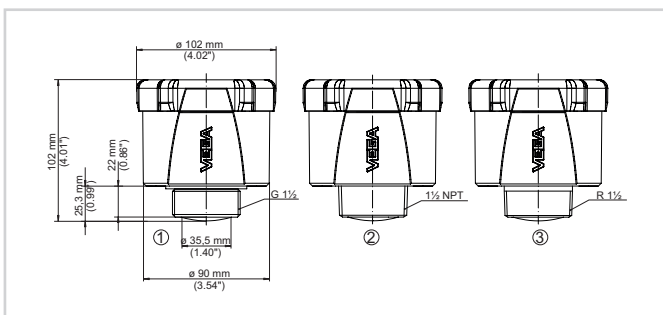

Dimensions VEGAPULS Air 41

- 1 Thread G
- 2 Thread NPT
- 3 Thread R

Information

You can find further information on the VEGA product line on our homepage.

In the download section on our homepage you'll find operating instructions, product information, brochures, approval documents, instrument drawings and much, much more.

Software accessories such as the current device software and the appropriate operating software are also available there.

Instrument selection

On our homepage under "Products" you can select the suitable measuring principle and instrument for your application.

There you will also find detailed information on the available device versions.

Contact

You can find your personal contact person at VEGA on our homepage under "Contact".