

In-Line Immersible Thermal Gas Mass Flow Meter with Flow Conditioning

FEATURES

- Direct mass flow monitoring eliminates need for separate temperature and pressure inputs
- Built-in flow conditioner which eliminates velocity-profile distortions caused by upstream disturbances
- Accuracy +/- 1% of reading plus 0.5% of full scale
- Patented Dry-Sense™ technology eliminates sensor drift
- State-of-the-art calibration facility insures a highly accurate calibration that matches the application
- Field validation of meter electronics and sensor resistance verifies flow meter performance
- One-second response to changes in flow rate
- FM, CSA, PED and ATEX certified for hazardous areas
- CE approved
- Multipoint options available
- Integrated purge option available
- Optional HART, Modbus and Profibus DP available, Foundation Fieldbus

FlatTrak™ 780S



DESCRIPTION

The FlatTrak™ 780S flow body eliminates velocity profile distortions, swirl and temperature stratifications in the gas stream and reduces the amount of upstream piping required for accurate flow measurement.

The versatile microprocessor-based transmitter integrates the functions of flow measurement, flow-range adjustment, meter validation and diagnostics, in either a probe-mounted or remote housing. Mass flow rate and totalized flow, as well as other configuration variables, are displayed on the meter's optional 2 x 12 LCD display. The programmable transmitter is easily configured via an RS-232 communication port and Sierra's Smart Interface™ software, or via the display and magnetic switches on the instrument panel.

Sierra's state-of-the-art calibration facility insures that the calibration will match the application, and our patented Dry-Sense™ thermal sensor insures the 640S will hold this calibration over time.

Sierra's Smart Interface™ software guides you through a procedure to fully validate instrument performance. The meter is available with a variety of input power, output signals, mounting and packaging options.



www.sierrainstruments.com



DIMENSIONAL SPECIFICATIONS

1/4-inch NPT—Front View (E2)

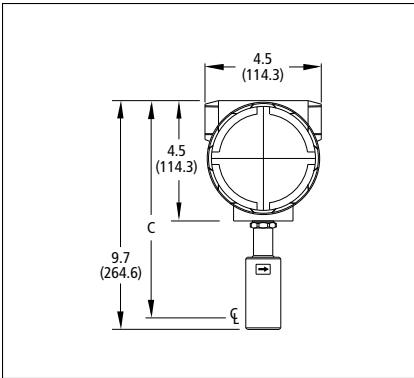

1/4-inch NPT—Side View (E2)

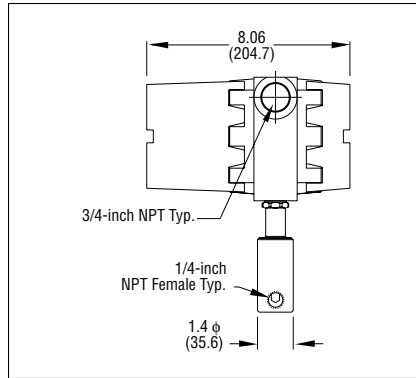

Sizes for NPT

Sizes For NPT			
Size	C	L1	L2
1/4-inch	8.40 (213.4)	—	—
1/2-inch	6.90 (175.3)	2.20 (55.9)	6.50 (165.1)
3/4-inch	6.90 (175.3)	2.20 (55.9)	7.00 (177.8)
1-inch	9.10 (228.6)	1.50 (38.1)	3.50 (88.9)
1.5-inch	9.40 (238.8)	2.25 (57.2)	5.25 (133.4)
2-inch	10.20 (259.1)	3.50 (88.9)	7.50 (190.5)
3-inch	11.20 (284.5)	4.00 (101.6)	10.00 (254)
4-inch	11.20 (284.5)	4.00 (101.6)	12.00 (304.8)
6-inch	12.20 (309.9)	6.00 (152.4)	18.00 (457.2)
8-inch	13.20 (335.3)	8.00 (203.2)	24.00 (609.6)

1/2-inch and 3/4-inch NPT—Front View (E2)

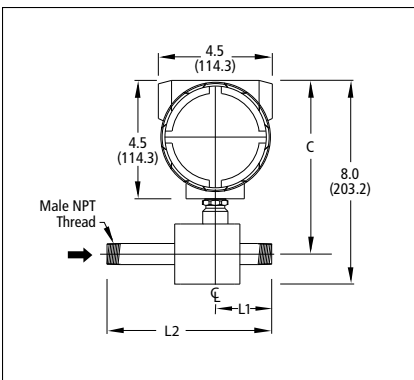

1/2-inch and 3/4-inch NPT—Side View (E2)

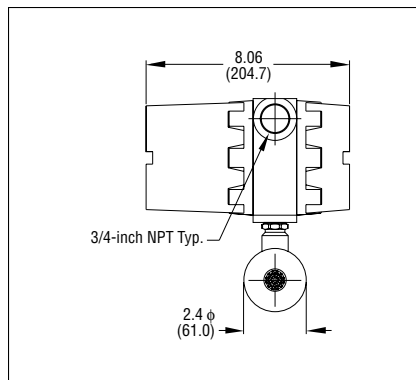

1-inch Through 8-Inch NPT—Front View (E2)

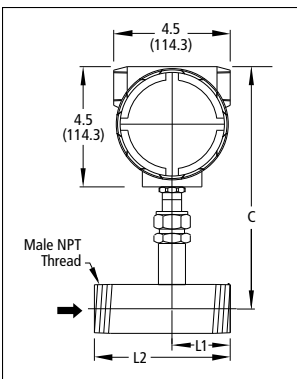

1-inch Through 8-Inch NPT—Side View (E2)

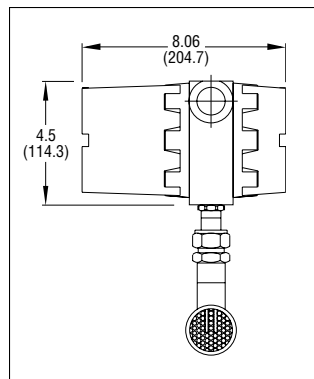

1-inch to 8-Inch NPT—Front/Side View (EN2)

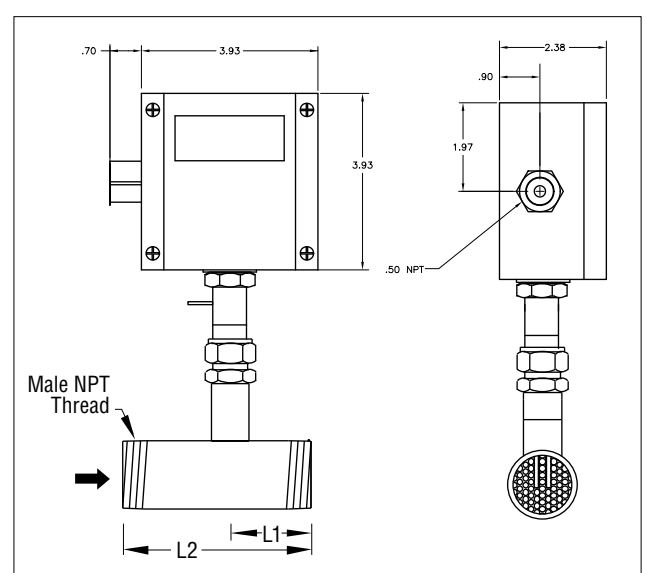

1/2 and 3/4-inch 150 lb Flange—Front View (E2)

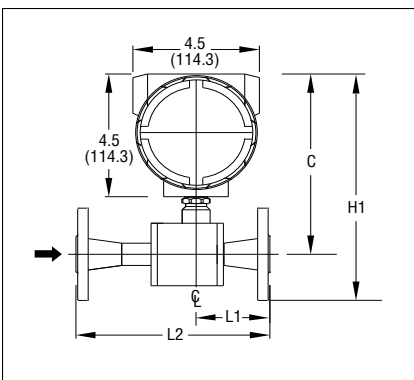

1/2 and 3/4-inch 150 lb Flange—Side View (E2)

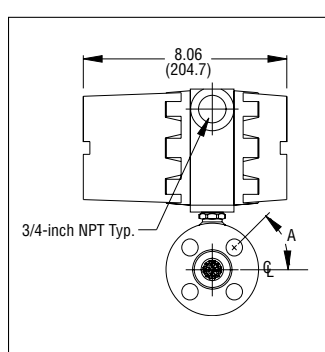

Sizes for 150 lb ANSI Flange

Sizes For 150 Lb Ansi Flanges					
Size	H1	C	L1	L2	A
1/2-inch	7.79 (197.9)	6.94 (176.3)	2.60 (66.0)	6.95 (176.5)	45°
3/2-inch	7.79 (197.9)	6.94 (176.3)	2.78 (70.6)	7.56 (192.0)	45°

All dimensions are inches. Millimeters are in parentheses. All drawings have a +/- .25-inch (6.4 mm) tolerance. Certified drawings are available on request.

1" Through 8" 150 lb Flange—Front View (E2)

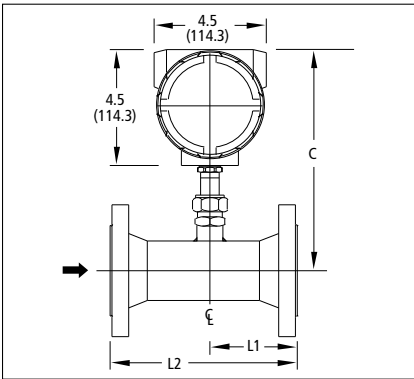

1" Through 8" 150 lb Flange—Side View (E2)

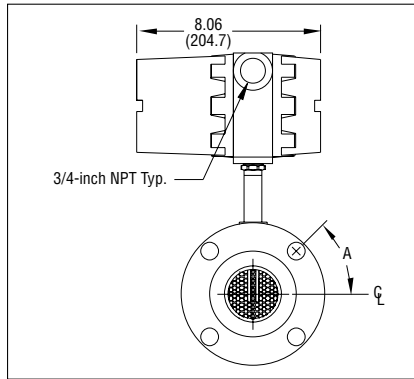

DN Flange—Front View (E2)

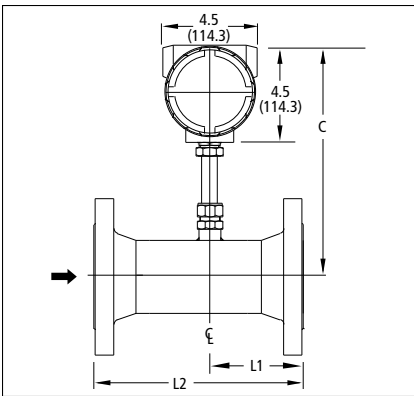

DN Flange—Side View (E2)

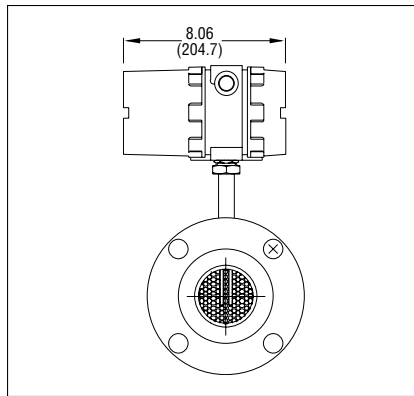

NEMA 4X Enclosure - Front View (EN2)

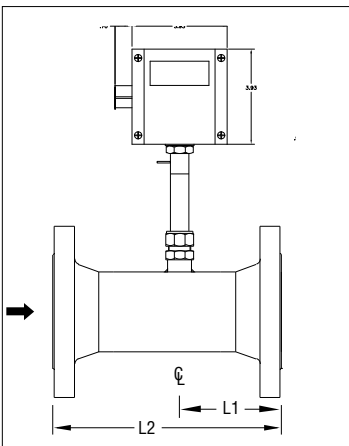

NEMA 4X Enclosure—Side View (EN2)

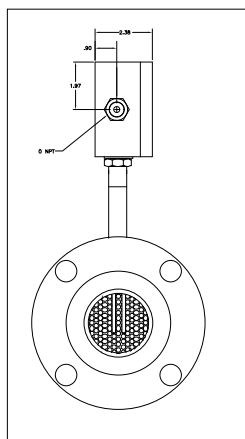

Remote Mounted with Junction Box (E4)

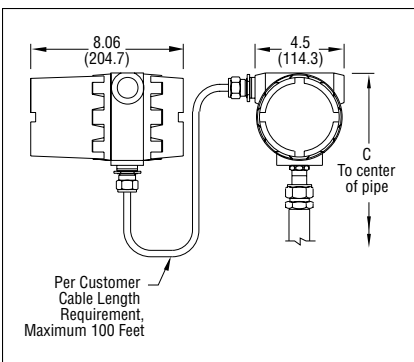

Remote Mounted with Junction Box (EN4)

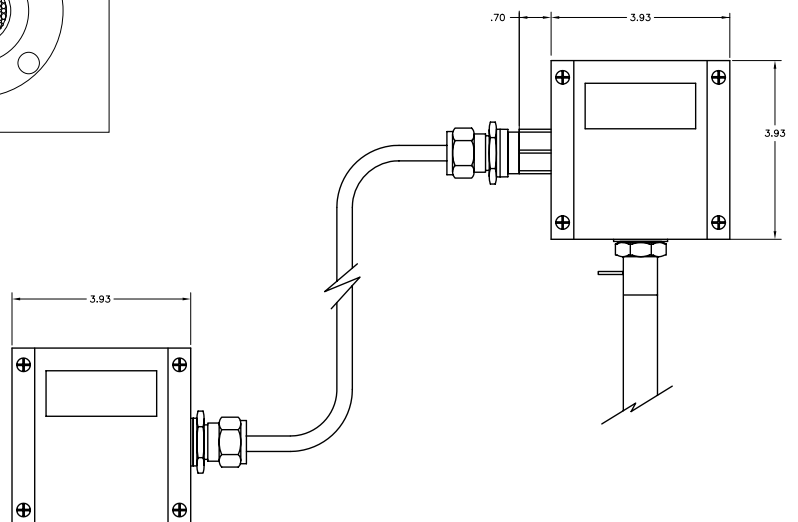

Sizes For 150 Lb Ansi Flanges				
Size	C	L1	L2	A
1-inch	9.10 (238.8)	3.60 (91.4)	7.40 (188.0)	45°
1.5-inch	9.40 (238.8)	3.80 (96.5)	7.56 (192.0)	45°
2-inch	10.20 (259.1)	3.50 (88.9)	7.50 (190.5)	45°
3-inch	11.20 (284.5)	4.00 (101.6)	12.00 (304.8)	22.5°
4-inch	11.20 (284.5)	4.00 (101.6)	12.00 (304.8)	22.5°
6-inch	12.20 (309.9)	6.00 (152.4)	18.00 (457.2)	22.5°
8-inch	13.20 (335.3)	8.00 (203.2)	24.00 (609.6)	22.5°

Sizes For PN16 DL Flanges			
Size	C	L1	L2
DN50	10.70 (271.8)	3.34 (84.8)	7.10 (180.3)
DN80	10.50 (266.7)	4.14 (105.2)	10.20 (259.1)
DN100	10.60 (269.2)	4.57 (116.1)	12.60 (320.0)
DN150	12.40 (315.0)	6.77 (172.0)	18.90 (480.1)
DN200	14.50 (368.3)	8.47 (215.1)	24.00 (619.8)

All dimensions are inches. Millimeters are in parentheses. All drawings have a +/- .25-inch (6.4 mm) tolerance. Certified drawings are available on request.

Sizes For Remote Mounted	
Size	C
1/4-inch	8.4 (198.1)
1/2-inch	6.9 (175.3)
3/4-inch	6.9 (175.3)
1-inch	9.10 (231.1)
1.5-inch	9.40 (238.8)
2-inch	10.20 (259.1)
3-inch	11.20 (284.5)
4-inch	11.20 (284.5)
6-inch	12.20 (309.9)
8-inch	13.20 (335.3)

PERFORMANCE SPECIFICATIONS

Accuracy

+/- 1% of reading + 0.5 % of full scale

Repeatability

+/- 0.2% of full scale

Temperature Coefficient

+/- 0.02% of reading per °F within +/- 50° F of customer specified conditions
 +/- 0.03% of reading per °F within +/- 50° F to 100° F of customer specified conditions
 +/- 0.04% of reading per °C within +/- 25° C of customer specified conditions
 +/- 0.06% of reading per °C within +/- 25° C to 50° C of customer specified conditions

Pressure Coefficient

.02% per psi for air, consult factory for other gases

Response Time

One second to 63% of final velocity value

OPERATING SPECIFICATIONS

Gases

Most gases compatible with 316 L stainless steel

Gas Pressure (2 limitations)

Mechanical design pressure:

Compression fittings: 500 psig (34.5 barg)

150 lb flange or PN16 DN (-40° F to 100° F): 230 psig (15.9 barg)

150 lb flange or PN16 DN (250° F): 185 psig (12.8 barg)

150 lb flange or PN16 DN (450° F): 155 psig (10.7 barg)

NPT (-40° F to 250° F): 500 psig (34.5 barg)

PERFORMANCE SPECIFICATIONS

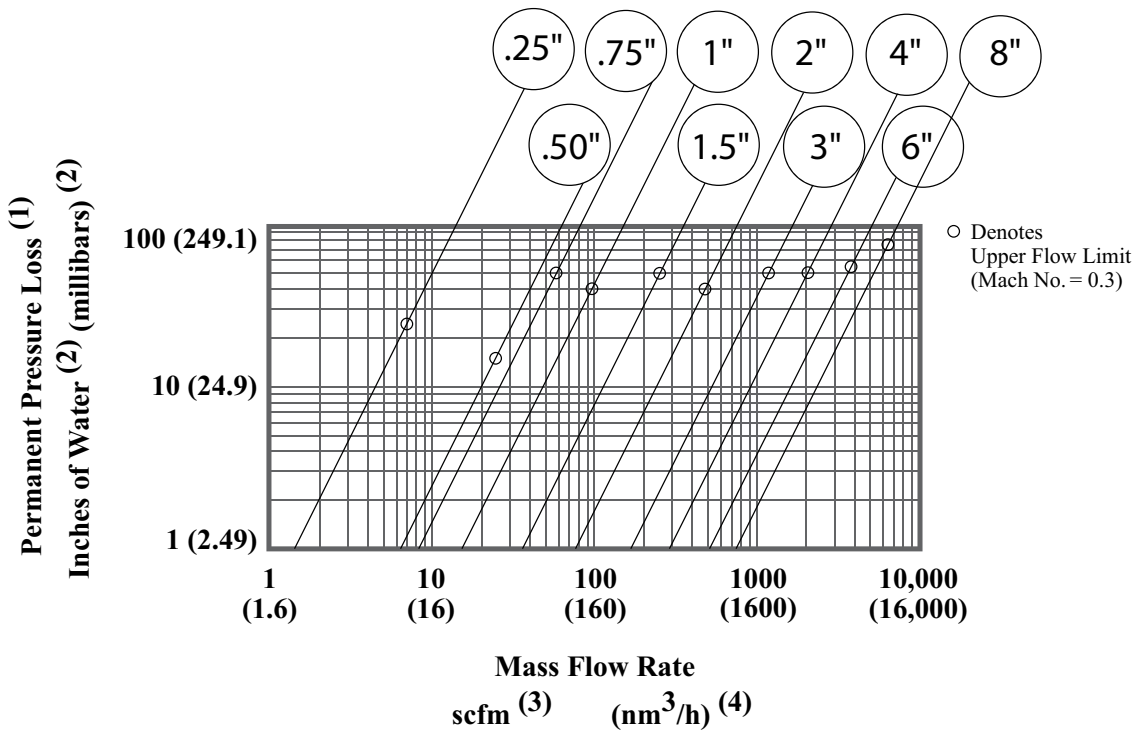

Notes:

- (1) For air and nitrogen at 20 °C temperature and 1 atmosphere pressure.
- (2) 1 inch of water at 60 °F = 0.0361 psi.
1 millibar = 0.001 bar = 100 pascal = 0.0145 psi.
- (3) At base conditions of 21.1 °C temperature and 1 atmosphere pressure.
- (4) At base conditions of 0 °C temperature and 1 atmosphere pressure.
- (5) Built-in flow conditioner consists of two separate perforated plates in series.

OPERATING SPECIFICATIONS (CONTINUED)

Gas & Ambient Temperature

Gas -40° F to 350° F (-40° C to 177° C)
 Ambient -40° F to 120° F (-40° C to 50° C)

Leak Integrity

5 X 10⁻⁹ cc/sec of helium maximum

Power Requirements

18 to 30 VDC (regulated), 625 mA maximum
 100 to 240 VAC, 50/60 Hz, 15 watts maximum
 625 mA maximum operating current at 24 VDC and full scale flow
 Maximum in rush current of 2 Amps at 24 VDC
 Consult factory for other conditions

Output Signal

Linear 0–5 VDC or 0-10 VDC, 1000 ohms minimum load resistance or
 Linear 4–20 mA proportional to mass flow rate,
 700 ohms maximum resistance power supply dependent
 User-selectable: Active non-galvanically separated or Passive
 galvanically separated (loop power required)
 See Digital Communications options below

Alarms

Hard contact user-adjustable high and low
 Dead band adjustable with Smart Interface™ software
 Relay ratings. Maximum 400 VDC or VAC (peak), 140 mA

Displays

Alphanumeric 2 x 12 digit backlit LCD
 Adjustable variables via on-board switches (password protected)
 or with Smart Interface™ software
 Adjustable variables Full scale (50 to 100 %)
 Time Response (1 to 7 seconds)
 Correction factor setting (0.5 to 5)
 Zero and span
 High and low alarm settings

Totalizer

Seven digits (9,999,999) in engineering units
 Resettable by software, on-board switches or external magnet

Software

Smart Interface™ Windows®-based software
 Minimum 8 MB of RAM, preferred 16 MB of RAM
 RS-232 communication
 Additional features Alarm dead band adjustment
 Zero cut-off adjustment
 Linearization adjustment
 Save / Load configurations
 Fully guided flow meter validation

DIGITAL COMMUNICATIONS OPTIONS

Pulse (1Hz max, not available with E2-NR)
 Modbus RTU (not available with P3 option)
 Profibus DP (available E2/E4-P2 configuration only)
 HART universal commands (available E2/E4-P2 configuration only)
 Foundation Fieldbus (available E2/E4-P2 configuration only)

PHYSICAL SPECIFICATIONS

Wetted Materials

316L stainless steel
 Carbon steel flow bodies available in some sizes

Enclosure

Hazardous-Area Location Enclosure (IP66) and NEMA 4X (IP65) are
 powder-coated cast aluminum

Electrical Connections

Two 3/4 inch NPTHazardous-Area Location Enclosure (IP66)
 One 1/2 inch NPTNEMA 4X Enclosure (IP65)

Piping Requirements

Straight Pipe Length Requirements at 1 ATM			
Piping Condition	780S FlatTrak™		Orifice Plate (3)
	Upstream	Downstream	
Single 90° Elbow or T-Piece	1D	0D	28D
Reduction (4:1)	3D	0D	14D
Expansion (4:1)	3D	0D	30D
After Control Valve	3D	0D	32D
Two 90° Elbows (In Same Plane)	3D	0D	36D
Two 90° Elbows (Different Plane)	5D	0D	62D

Notes: (1) Number of diameters (D) of straight pipe required between upstream disturbance and the flow meter.
 (2) Number of diameters (D) of straight pipe required downstream of the flow meter.
 (3) For comparison purposes only. Table shows number of diameters (D) of upstream straight pipe length required for an ISO Standard 5167 Orifice Plate with a Beta Ratio of 0.7.
 (4) Consult factory for pressure effects.

Certifications

CE (All enclosures)
 CSA (Explosion proof for Class I, Division 1, Groups B, C, D)
 ATEX (II 2 GD Ex d IIC T6 ... T2; IP 66 T70 °C ... T280 °C)
 FM (Explosion proof for Class I, Division 1, Groups B, C, D; dust-ignition proof for Class II, III, Division 1, Groups E, F, G)
 IP65, NEMA 4X T6 -40° C to 70° C ambient
 PED optional

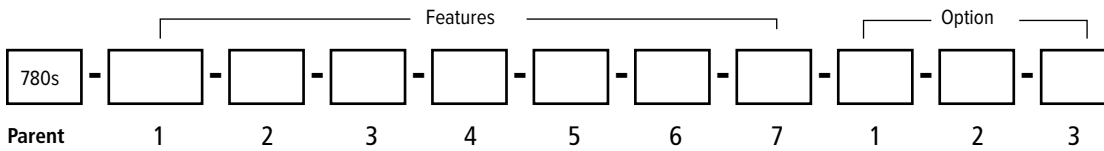

Instructions: To order a 780S please fill in each number block by selecting the codes from the corresponding features below and following pages.

Parent Model Number	
780S	FlatTrak™ In-line Mass Flow Meter with Flow Conditioner. All 316 stainless steel construction. UHP 5-10 RA available. 18-30 VDC or 100-240VAC input power with 3/4-inch diam 316SS probe. Includes "Smart Electronics" with PC configuration software. Calibration temperatures up to 350°F (176°C) and pressure to 500 psig (34.5 barg). CE, FM, CSA, ATEX approvals. Linear 0-5 VDC or 4-20 mA output signals. Lifetime warranty on non-UHP Fast Response (FR) sensor

Note: The following lists standard product/pricing. Sierra will work with you for special requests. Please submit your request using the RFQ/Specials tab in this price list.

Feature 1: Approvals	
NAA	Non-agency approved meter
ATEX	780S with II 2 GD Ex d IIC T2...T6 ATEX Approval. Requires E2 or E3 enclosure. Note: ATEX units have circuit energy limitations that limit maximum flows to approx. 50% of non-ATEX units. Consult gas tables for details.
FM	780S with FM approval. Requires E2 or E4 enclosure
CSA	780S with CSA approval. Requires E2 or E4 enclosure

Feature 2: Body Size-NPT*	
N1	1/4-inch NPT Female 316SS
N2	1/2-inch NPT Male 316SS
N3	3/4-inch NPT Male 316SS
N4	1-inch NPT Male 316SS
N5	1.5-inch NPT Male 316SS
N6	2-inch NPT Male 316SS
N7	3-inch NPT Male 316SS
N8	4-inch NPT Male 316SS
N9	6-inch NPT Male 316SS
N10	8-inch NPT Male 316SS

Feature 2: Body Size-ANSI 150*	
F2	1/2-inch ANSI class 150 flange 316SS
F3	3/4-inch ANSI class 150 flange 316SS
F4	1-inch ANSI class 150 flange 316SS
F5	1.5-inch ANSI class 150 flange 316SS
F6	2-inch ANSI class 150 flange 316SS
F7	3-inch ANSI class 150 flange 316SS
F8	4-inch ANSI class 150 flange 316SS
F9	6-inch ANSI class 150 flange 316SS
F10	8 inch ANSI class 150 flange 316SS

Feature 2: Body Size-PN 16*	
FD6	DN50, PN16, DIN flange
FD7	DN80, PN16, DIN flange
FD8	DN100, PN16, DIN flange
FD9	DN150, PN16, DIN flange
FD10	DN200, PN16, DIN flange

Feature 2: Body Size-PN 40	
GD4	DN25, PN40, DIN flange
GD5	DN40, PN40, DIN flange
GD6	DN50, PN40, DIN flange
GD7	DN80, PN40, DIN flange
GD8	DN100, PN40, DIN flange
GD9	DN150, PN40, DIN flange
GD10	DN200, PN40, DIN flange

Note: Carbon steel, Hastelloy®, PVC, and Kynar flow bodies are available. Consult Factory for information.

Feature 3: Electronics Enclosure	
E2	Hazardous-area location enclosure (IP66). Mounted directly on probe
E3 ()	Remote hazardous-area location enclosure (IP66). Specify cable length in parenthesis. Maximum 200 feet (61m) (IP66) housing mounted up to 200 feet (61m) from flow body; includes strain relief on end of probe and mounting bracket. Specify cable length between brackets
E4 ()	Remote hazardous-area location Enclosure (IP66) with junction box specify cable length in parenthesis. Maximum 200 feet (61m) (IP66) housing mounted up to 200 feet (61m) from flow body; includes (IP66) junction box mounted on probe and mounting bracket (304SS) Specify cable length between brackets
EN2	NEMA 4X (IP65) Enclosure. Mounted directly on probe.
EN4 ()	Remote NEMA 4X (IP65) enclosure with junction box. Specify cable length in parenthesis. Maximum 200 feet (61m). Mounted up to 200 feet (61m) away from the probe with junction box mounted on probe. Includes remote electronics enclosure mounting bracket and 1/2-inch Female NPT connection. Specify cable length between brackets

Feature 4: Input Power	
P2	18–30 VDC
P3	100–240 VAC. Not available with EN enclosures.

Feature 5: Output	
V1	0–5 VDC, linear
V3	0-10 VDC, linear
V4	4-20 mA, linear

Feature 6 : Display	
NR	No Readout
DD	Digital display. 2 x 12 digit, backlit, LCD display indicates flow rate and totalized mass in engineering units. Simplifies configuration settings and provides system status information
DD-NRT	Totalizer cannot be reset in the field.

Feature 7: Gas	
0	Air
1	Argon
2	Carbon dioxide
3	Chlorine ¹
4	Digester gas
5	Digester gas ¹
6	Helium
7	Hydrogen
7C	Hydrogen ¹
8	Methane
9	Methane ¹
10	Nitrogen
11	Oxygen ¹
12	Propane
13	Propane ¹
14	Ammonia ¹
99	Other--Consult Factory Gas Table

Option 1 : Digital Communications	
Pulse	Totalizer pulse output (Only available with E2/E3/E4 enclosures WITH DD. Available on ALL EN2 Enclosures)
DP1	Profibus DP using an M12 connector (available E2/ E4–P2, NAA only) with full device description
DP2	Profibus DP using a 2-wire terminal block connection (available E2/ E4–P2 config only) with full device description; FM approval available
MB	Modbus RTU with full device description (P2 only); ATEX and FM approvals available
FF	Foundation Fieldbus with full device description (available E2/ E4–P2 config only); FM approval available
HART	HART universal variables; flow totalizer, K-factor, user full scale, and instantaneous flow (available E2-P2 /E4-P2) config only). FM approval available.

Note: All except Pulse require DC power (P2).

Option 2: Certificates	
MC	Material certificates--US Mill certs on all wetted parts
PED	Manufactured according to PED directive
CC	Certificate of conformance
NACE	NACE certificate for sour gas
LT	Leak test certificate
PT	Pressure test certificate

Option 3: O2 Cleaning	
O2C	O2 Cleaning. Meters up to 4 inches (DN100). Includes certification. Product cleaned for O2 service. Inspected with Ultra-Violet light, double-bagged prior to shipment.

Note: Consult factory for O2 Cleaning of meters over 4-inches (DN100).

¹Correlation calibration - consult Gas Table for accuracy.
Note: Consult Product Data Sheet for flow rate, pressure, and temperature limits.

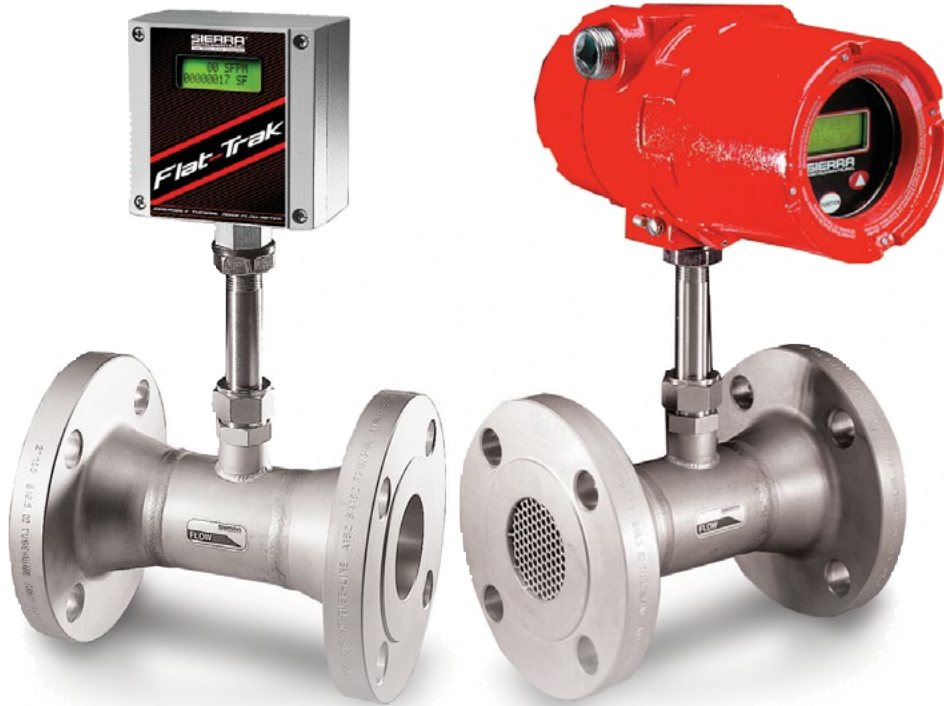

www.sierrainstruments.com

SIERRA INSTRUMENTS, NORTH AMERICA • 5 HARRIS COURT, BUILDING L • MONTEREY, CALIFORNIA 93940 • (800) 866-0200 • (831) 373-0200 • FAX (831) 373-4402 • WWW.SIERRAINSTRUMENTS.COM

SIERRA INSTRUMENTS, EUROPE • BUILMANSWEID 2 • 1934RE EGMOND AAN DEN HOEF • THE NETHERLANDS • +31 72 5071400 • FAX: +31 72 5071401

SIERRA INSTRUMENTS, ASIA • SECOND FLOOR BUILDING 5 • SENPU INDUSTRIAL PARK • 25 HANGDU ROAD HANGTOU TOWN • PU DONG NEW DISTRICT • SHANGHAI, P.R. CHINA 201316 • +8621 5879 8521/22 • FAX: +8621 5879 8586